

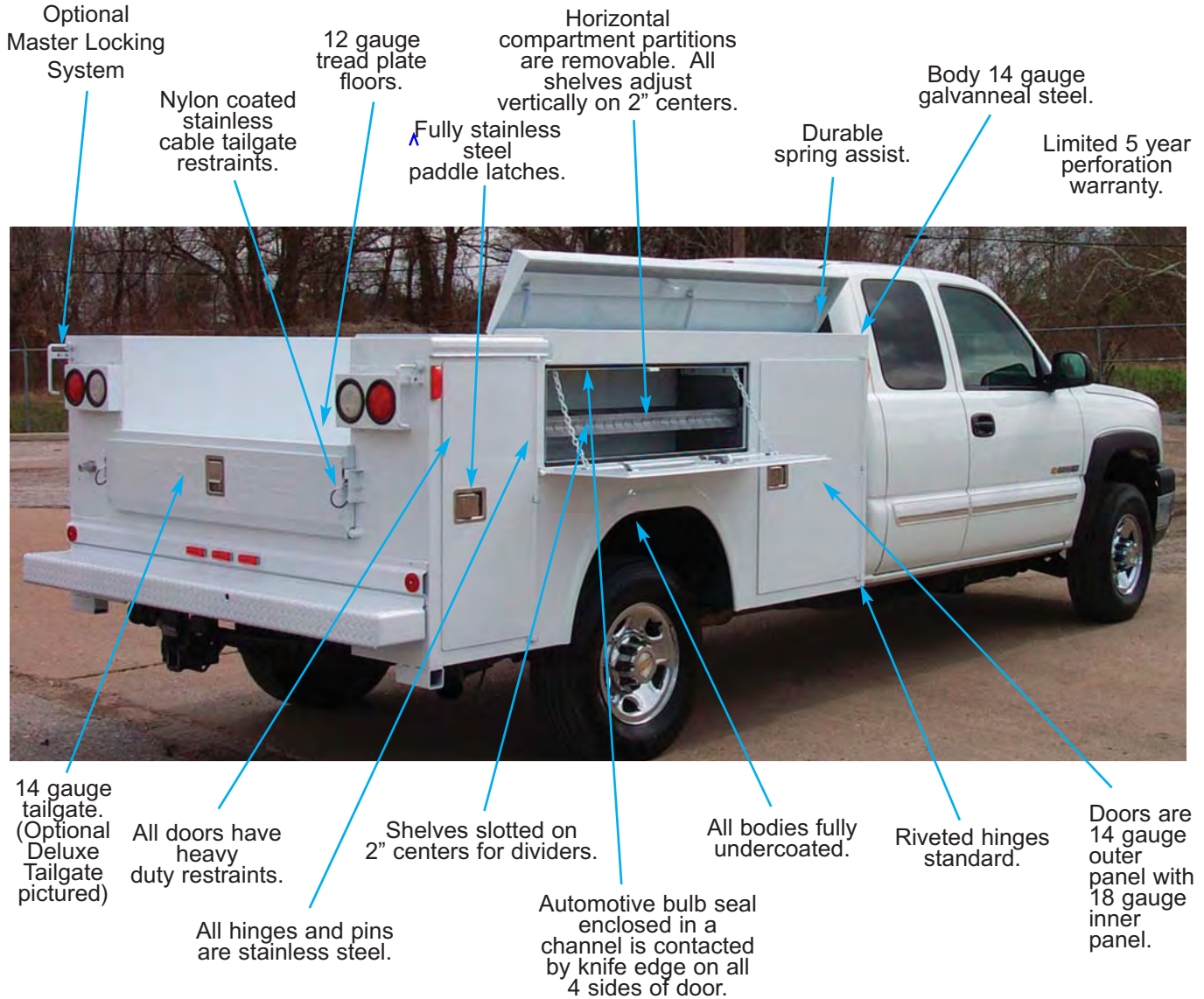

Top opening compartments shown in picture are OPTIONAL!!!

FEATURES



Pictured above is an RKI crane reinforced LT5680 (L-Series Streetside, T-Series Curbside) Service Body

WEATHER PROTECTION SYSTEM

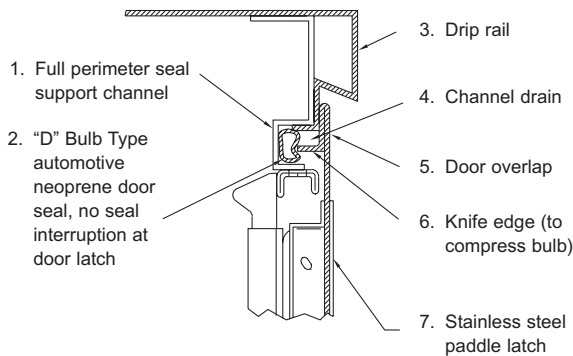

STAINLESS STEEL HINGE SYSTEM

